

DD BOX 12/12 T6 1,1kW

GENERAL DATA



CENTRIFUGAL DIRECT DRIVE FAN WITH FORWARD CURVED IMPELLER IN SOUNDPROOF CABINET

MANUFACTURING FEATURES:

- Impellers made of polyamide reinforced with fiberglass up to size 33/33 (12/12). Rest of models made of galvanized steel sheet.
- DD range fans assembled in soundproof cabinets with thermo-acoustic elastomer insulation, M1 fire resistance.
- Fan assembled on antivibration mountings.
- Connection gland included.
- Closed motors specially designed with extruded aluminum housing, which make the whole connection is protected within the integrated terminal box on the motor with IP-65 protection. Motor with IP-54 protection and Class F insulation standard voltages: 230V 50Hz in single phase and 230/400 V three-phase motors.

APPLICATIONS:

Designed for inline installation, indoor or outdoor assembly, they are suitable for:

- Air renewal in buildings and industries.
- Industrial and professional kitchen hoods.
- Maximum working temperature: 50°C.

UNDER REQUEST:

- 3 speed fans.
- LG0 position.
- Impellers made of galvanised steel sheet.

PERFORMANCE CURVE

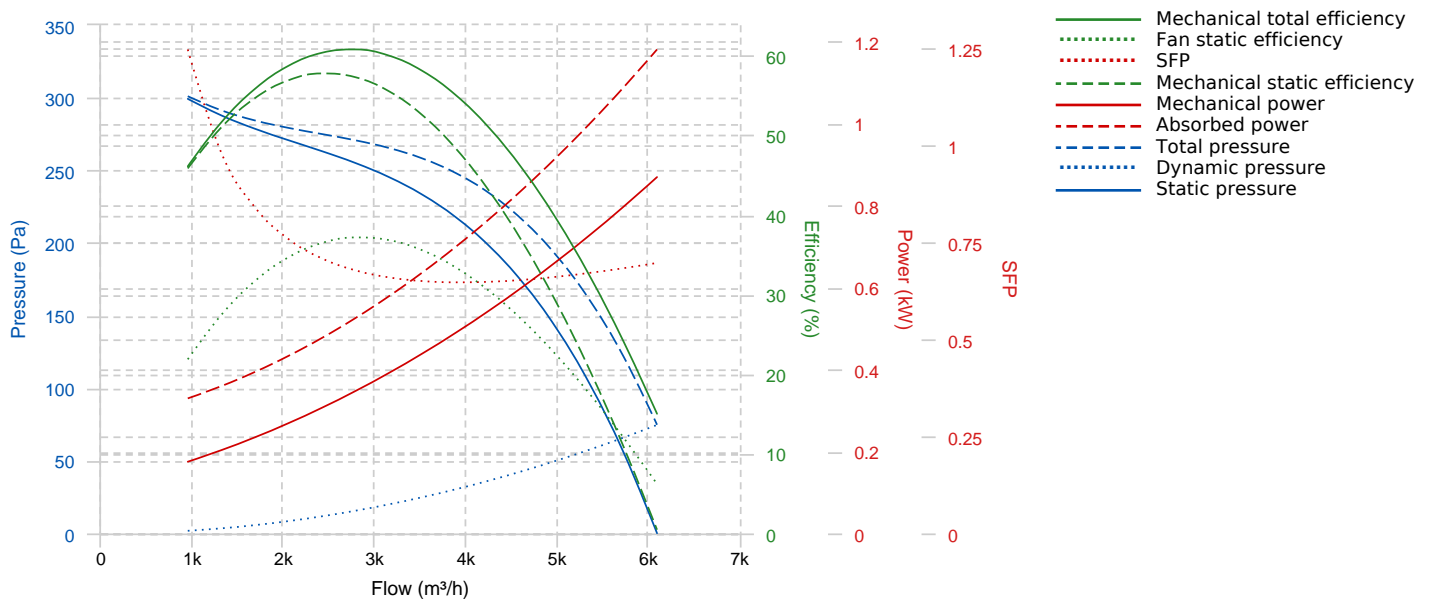

TECHNICAL DATA

Fan							
RPM	945	Approx. weight	51 kg	Max. Flow	6100 m ³ /h		
Motor							
Power	1,1 kW	RPM	945	I max. (230V)	6,54 A	I max. (400V)	3,78 A
Size	STC90	Approx. weight	10.6 kg	Efficiency (%)	78.1 %	FP	0.71

DIMENSIONS

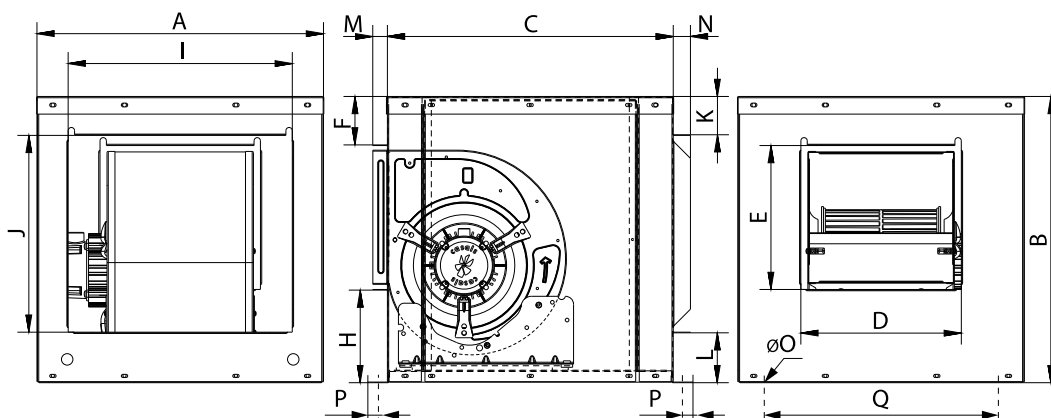

Dimensions (mm)									
A	650	B	650	C	650	D	408	E	349
F	83	H	216	I	576	J	500	K	65
L	83	M	23	N	27	O	10	P	17
Q	592,4								

WIRING DIAGRAM

230V 

400V 

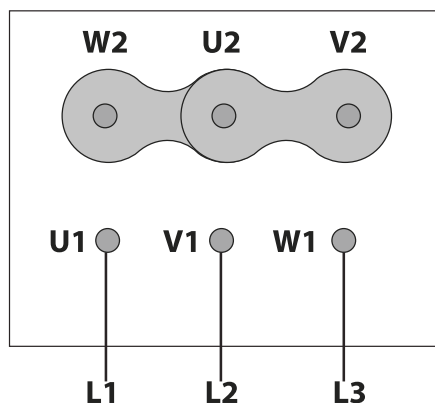
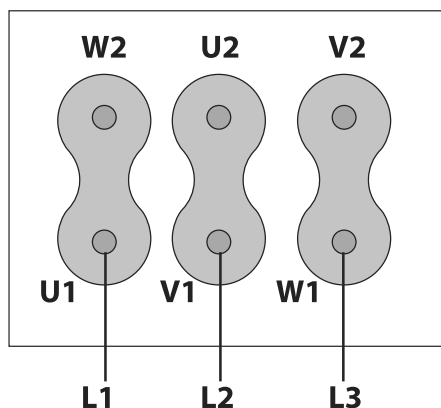

ACCESSORIES



SAFETY SWITCH
INT 25 3P A



INLET BLIND COVER
TCA 9



OUTDOOR FLANGE WITH BIRD GUARD
VIS OUT 12



OUTDOOR FLANGE WITH BIRD GUARD
VIS IN 12



RECTANGULAR-CIRCULAR ANTI-VIBRATION FLANGE
BAC 15 (IN BOX BD/BV 12/12)



FREQUENCY SPEED CONTROLLER
SFC 400 III 5A *



METALLIC GRAVITY SHUTTER FOR CABINET FANS. CERTIFIED 400°C/2H
PI 33/33 (12/12)



INLET/OUTLET ROUND COVER
TIAC 4 (OUT)



INLET/OUTLET ROUND COVER
TIAC 15 (IN)

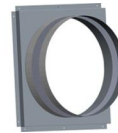

RECTANGULAR-CIRCULAR ANTI-VIBRATION FLANGE
BAC 4 (OUT 12/12)



FREQUENCY SPEED CONTROLLER
SFC 230 I 7A *

SPARE PARTS

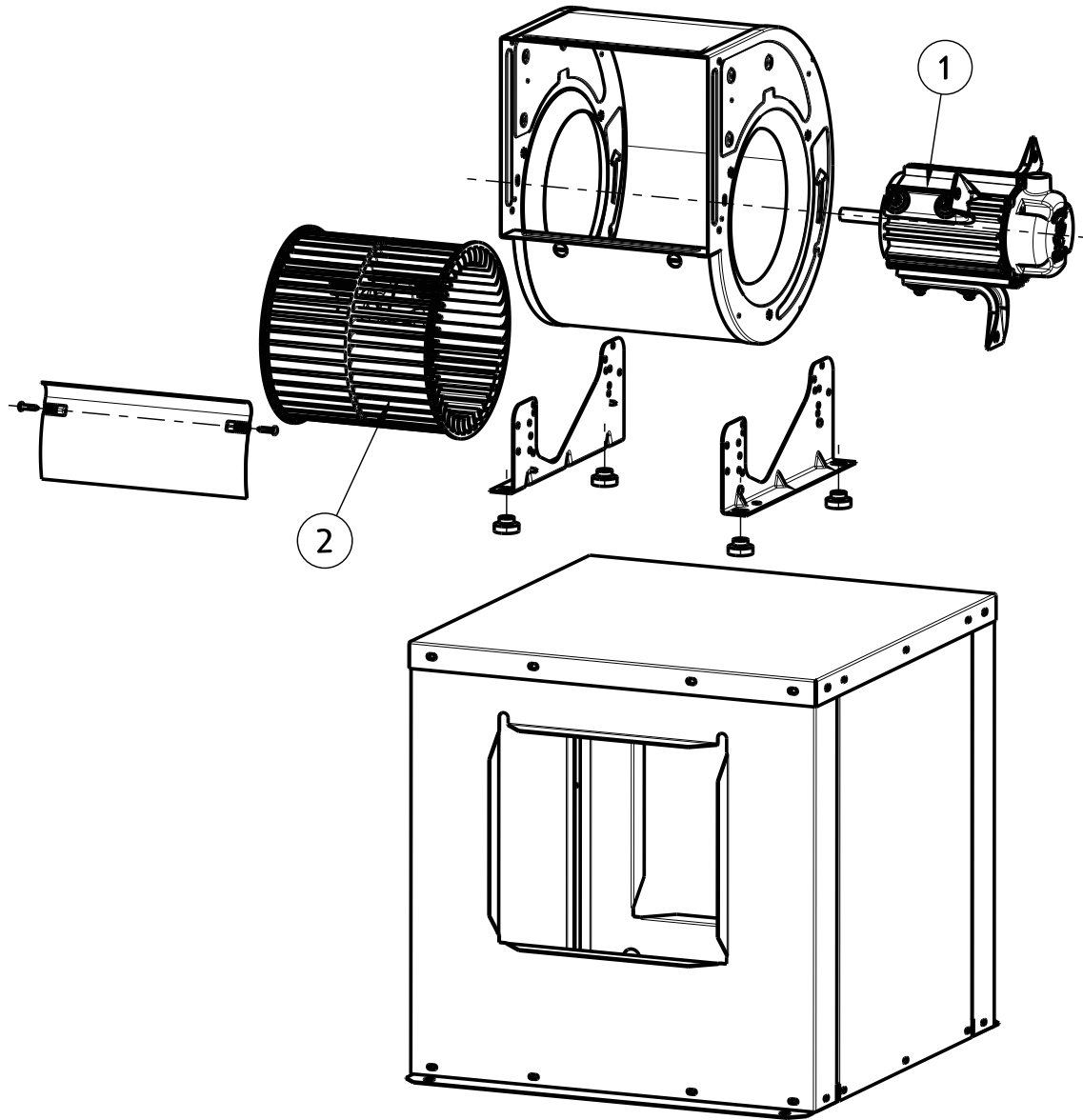

	Code	Model	Qty
1	251529477	MOTOR+SUPPORTS BD33T6-1,5 M/C	x1
1	721081250	MOTOR BD T6 1,1kW 230/400V	x1
2	R-251529383	IMPELLER PA6 BD12/12	x1