

SWA 35 M4

GENERAL DATA



SQUARE WALL PLATE AXIAL DIRECT DRIVE FAN WITH ALUMINUM IMPELLER

MANUFACTURING FEATURES

- Square plate made of galvanized steel sheet.
- Aluminum sheet impeller.
- Supplied with motor support and protection guard according to the UNE-EN 294 standard.
- Shaded-pole asynchronous motor, rated Class F isolation and IP-42.

APPLICATIONS

- Designed for wall assembly, they are suitable for:
- Air renewal in all kind of closed environments.
 - Maximum working temperature: 50°C.

PERFORMANCE CURVE

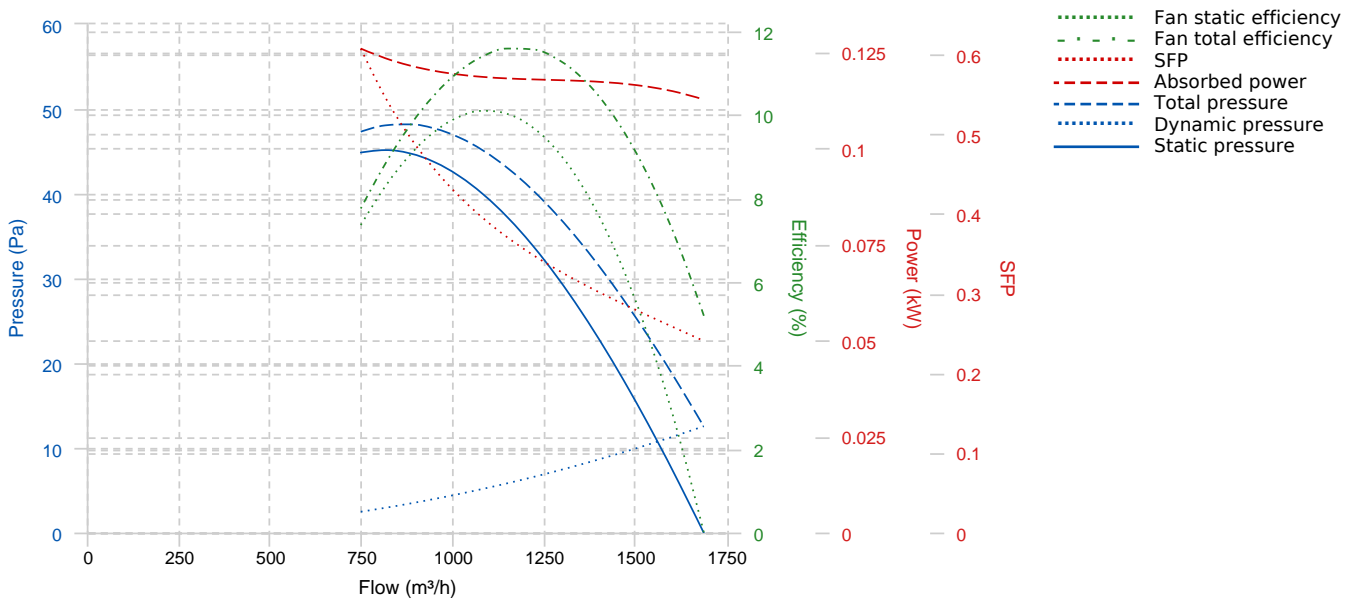

TECHNICAL DATA

Fan

RPM	1300	Approx. weight	4 kg	Max. Flow	1690 m³/h
-----	------	----------------	------	-----------	-----------

Motor

Power	0,034 kW	RPM	1300	I max. (230V)	0,75 A
-------	----------	-----	------	---------------	--------

DIMENSIONS

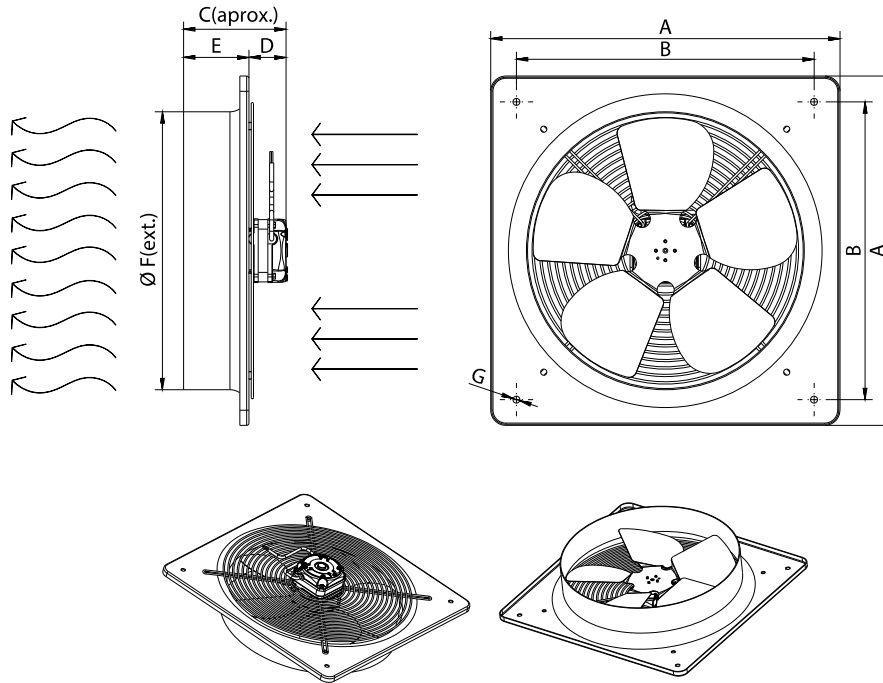

Dimensions (mm)

A	460	B	392	C	160	D	74	E	86
ØF	361	ØG	9						

WIRING DIAGRAM

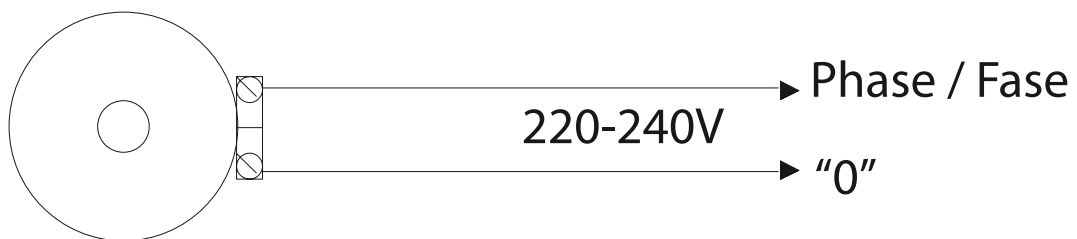

ACCESSORIES



**MANUAL SINGLE PHASE SPEED CONTROLLER
REG 1.5A**



**SAFETY SWITCH
INT 25 3P A**



Outlet protection guard for axial fans
RPO 35



MANUAL SINGLE PHASE SPEED CONTROLLER
REGD-1

SPARE PARTS

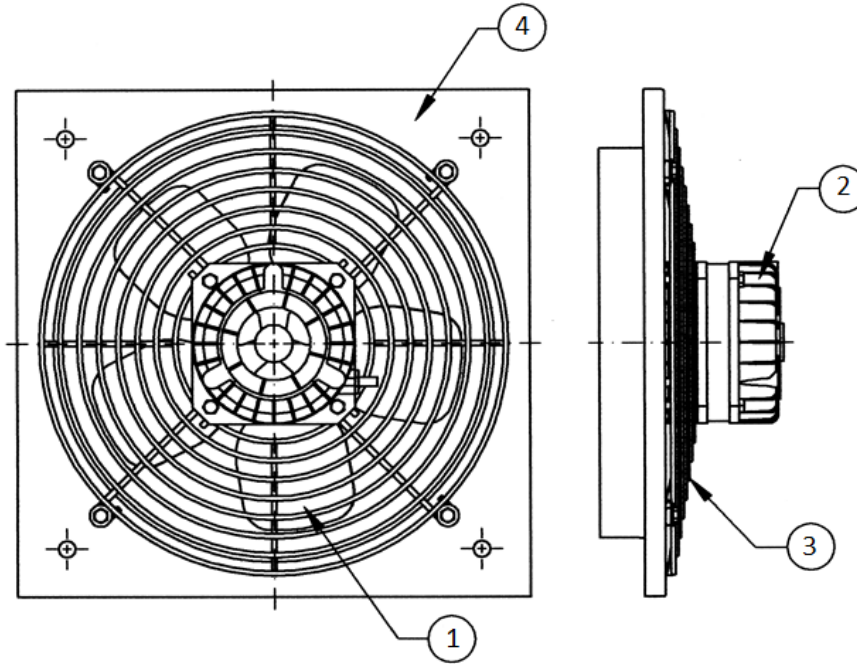

	Code	Model	Qty
1	R-265303650	IMPELLER HJEM35 350/20 ALUMINIO	x1
2	R-720001012	MOTOR 34W M4 230V (HJEM)	x1
3	R-265351905	PROTECTION GRID HJEM35	x1