

SCAX FIRE 100 T4 (A6:3) F300

GENERAL DATA

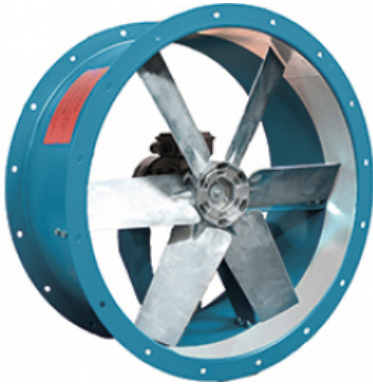

ATEX SHORT CASING AXIAL SMOKE FAN WITH CAST ALUMINUM IMPELLER DIRECT DRIVE - 300°C/1h

MANUFACTURING FEATURES:

- Axial fan short casing with circular reinforced frame.
- Modular motor-impeller assembly.
- Cast aluminum impeller with variable pitch angle.
- Polyester powder finishing coat.
- Standard asynchronous squirrel-cage motor with IP-55 protection and Class H insulation certified 300°C/1h and ATEX. Manufactured with standard voltages: 230/400V 50Hz in three phase motors up to 4kW and 400/690V 50Hz for higher powers.
- ATEX certified II 3G EX-ed IIC T3 Gc & II 3D EX-tc IIB T125 Dc

APPLICATIONS:

- Designed for inline installation, they are suitable for:
- Smoke emergency exhaust with motor inside the hazardous area.
 - Maximum working temperature: 60°C.

UNDER REQUEST:

- Supply impeller (air direction from impeller to motor).
- 100% reversible impeller.

Official homologation by the European laboratory APPLUS according to EN 12101-3:2015 Certification Nr: 0370-CPR-2407

PERFORMANCE CURVE

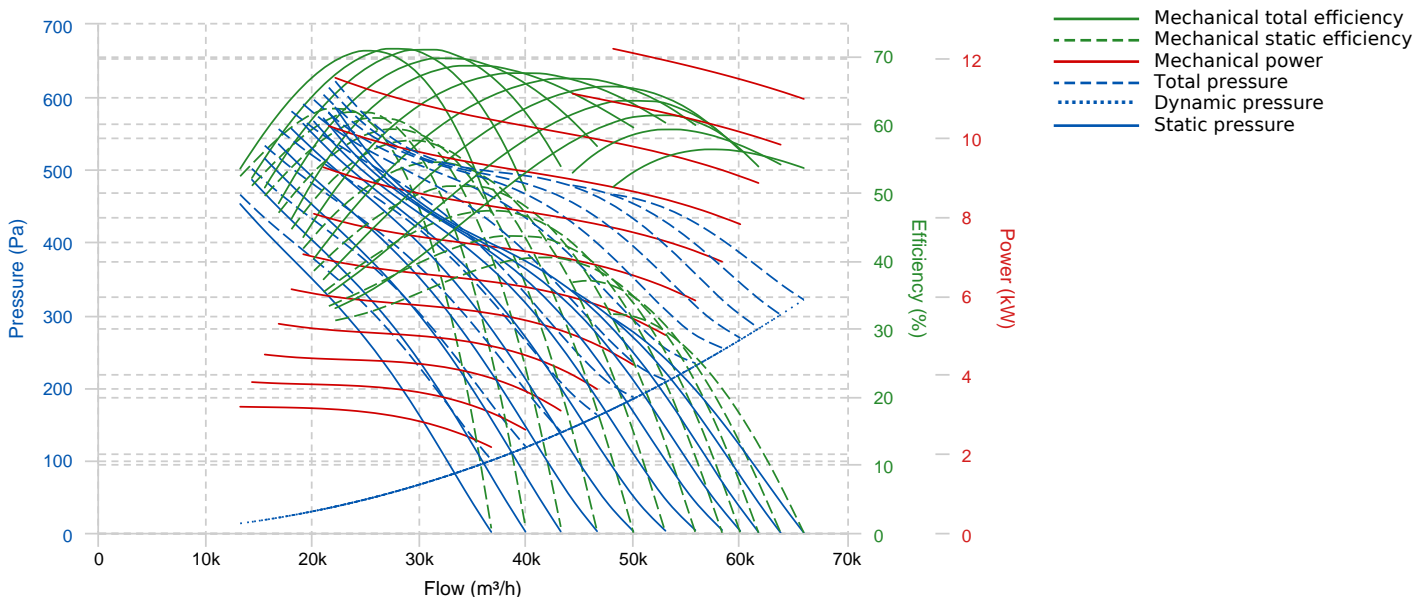

TECHNICAL DATA

Fan

RPM	-	Approx. weight	-	Max. Flow	65950 m ³ /h
-----	---	----------------	---	-----------	-------------------------

DIMENSIONS

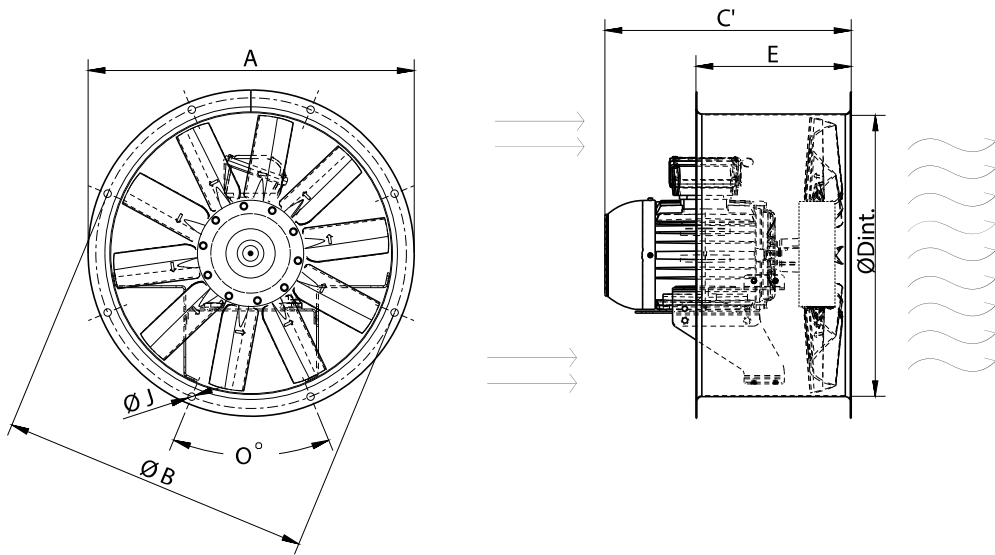

Dimensions (mm)

C' (Mot.T. 132)	655	C' (Mot.T. 160L)	762	C' (Mot.T. 160M)	718	C' (Mot.T. 180L)	794	C' (Mot.T. 180M)	756
E	425	O	16x22,5 ^ø	ØA	1115	ØB	1070	ØD	1013
ØJ	12								

WIRING DIAGRAM

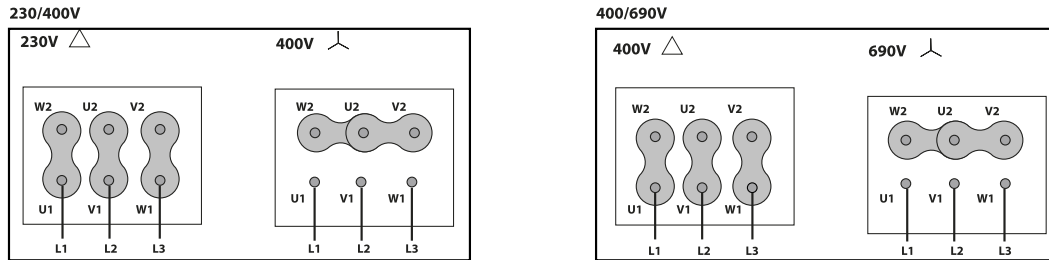

ACCESSORIES



**PROTECTION GUARD FOR LONG CASE FANS
RP 100**



**CONNECTION FLANGE
AC 1000**



**CIRCULAR-CIRCULAR ANTI-VIBRATION FLANGE
BAD 19**



**SAFETY SWITCH FOR 400°C/2h
INT F400 (GENERIC)**



**ANTI-VIBRATION SPRING BLOCK
AVS (GENERIC)**



**CASE FANS MOUNTING SUPPORT
MFLCA 100**



**ANTI-VIBRATING FLANGE 400°/2H
BA-400 100**



**SAFETY SWITCH
INT (GENERIC)**



**FREQUENCY SPEED CONTROLLER
SFC (GENERIC)**



**CIRCULAR SILENCER
SIL-C 1000/1000**