

BOX CA FIRE 50 T6 (A2:9) F300

GENERAL DATA



AXIAL SMOKE FAN WITH CAST ALUMINUM IMPELLER DIRECT DRIVE IN SOUNDPROOF CABINET - 300°C/1H

MANUFACTURING FEATURES

- BOX: Manufactured in galvanised steel sheet with thermalproofing. Soundproofing cabinets with thermo-acoustic insulation, Bs1d0 fire class. Removable panels for easy motor access and fan maintenance.
- INSIDE FAN: For sizes from 45 to 80 we use model WMA FIRE F300. For larger sizes from 90 to 125 we use model SCA FIRE F300.
- Modular motor-impeller assembly.
- Cast aluminum impeller with variable pitch angle.
- Polyester powder finishing coat.
- Standard asynchronous squirrel-cage motor with IP-55 protection and Class H insulation certified 300°C/1H. Manufactured with standard voltages: 230/400V 50Hz in three phase motors up to 4kW and 400/690V 50Hz for higher powers.

APPLICATIONS

Designed for wall or duct installation, they are suitable for:

- Smoke emergency exhaust with motor inside the hazardous area.
- Cabinet design simplifies installation in rectangular duct systems.
- Maximum working temperature: 60°C.

UNDER REQUEST

- Supply 100% reversible impeller.

Official homologation by the European laboratory APPLUS according to EN 12101-3:2015
Certification Nr: 0370-CPR-2405

PERFORMANCE CURVE

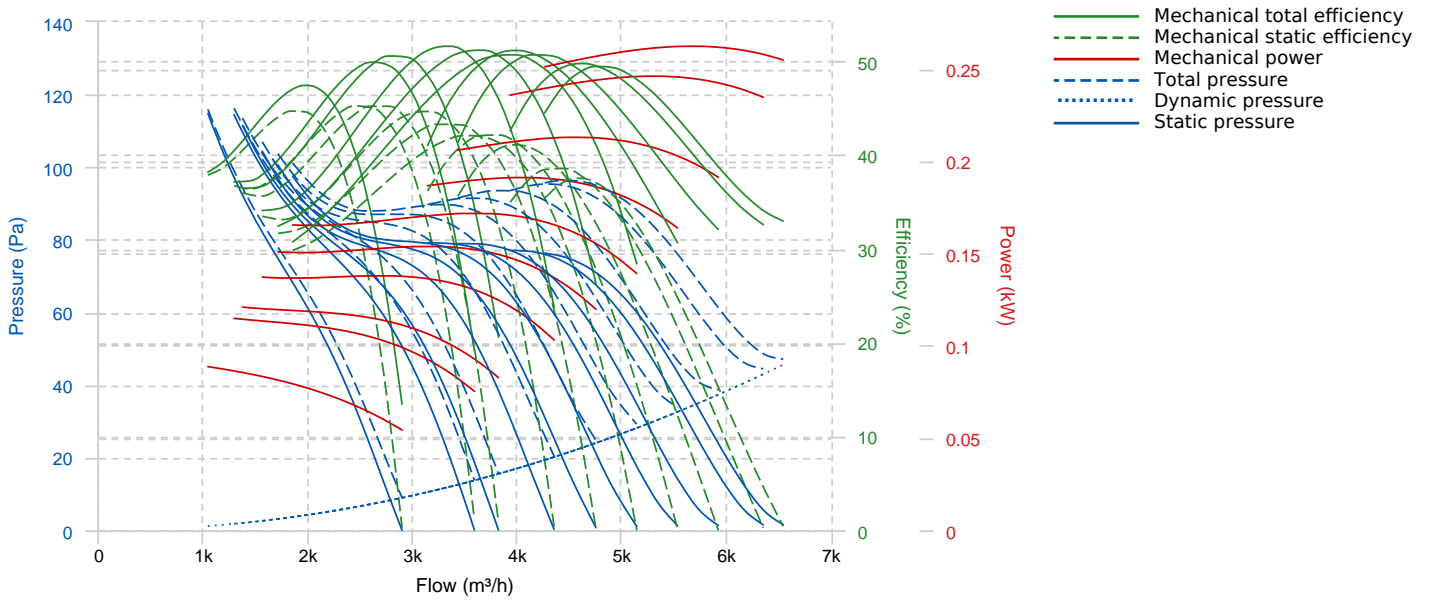

TECHNICAL DATA

Fan

RPM

-

Approx. weight

-

Max. Flow

6550 m³/h

DIMENSIONS

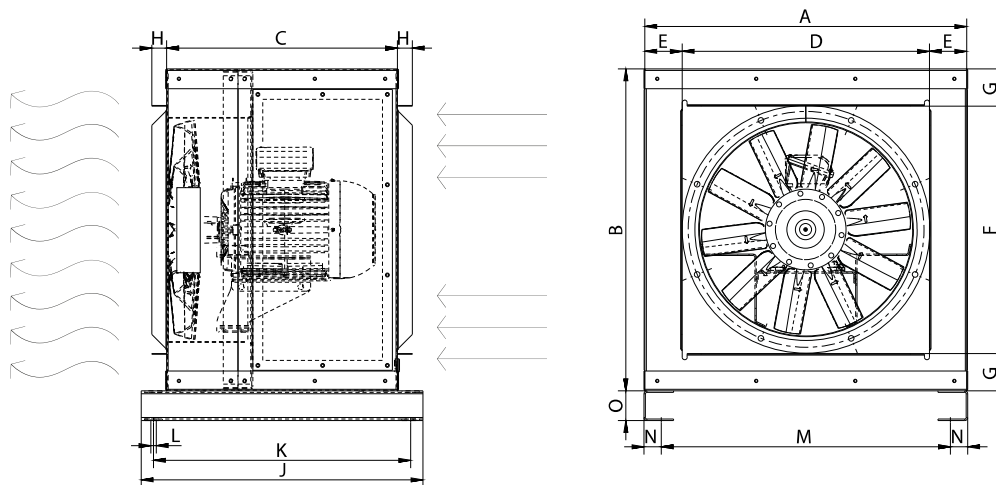

Dimensions (mm)

A	651	B	651	C	467	D	500	E	75
---	-----	---	-----	---	-----	---	-----	---	----

Dimensions (mm)

F	500	G	75	H	30	J	570	K	520
L	11	M	585	N	35	O	60		

WIRING DIAGRAM

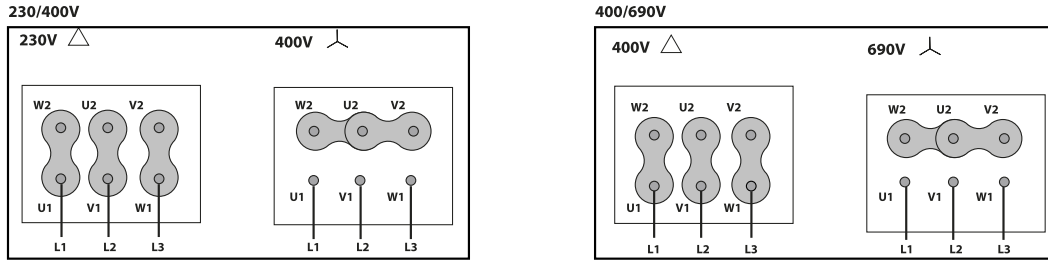

ACCESSORIES



FREQUENCY SPEED CONTROLLER SFC (GENERIC)



SAFETY SWITCH INT (GENERIC)



SAFETY SWITCH FOR 400°C/2h INT F400 (GENERIC)



ANTI-VIBRATION SPRING BLOCK AVS (GENERIC)