

BOX CAP 63 T6 (A2:9)

GENERAL DATA



AXIAL DIRECT DRIVE FAN WITH POLYPROPYLENE OR POLYAMIDE IMPELLER IN SOUNDPROOF CABINET

MANUFACTURING FEATURES:

- BOX: Soundproof galvanised steel box with thermo-acoustic elastomer insulation, M1 fire resistance. Easy motor access and fan maintenance through removable panels.
- INSIDE FAN: For size from 45 to 80 we use model WMAP. For larger sizes from 90 to 125 we use model SCAP .
- Motor-impeller assembly through a modular system.
- Variable pitch angle Polypropylene impeller (A2 profile) or polyamide impeller reinforced with fibreglass (other profiles).
- Polyester powder finishing coat.
- Squirrel cage asynchronous standard motor, IP-55 protection and rated class F insulation. Standard voltages 230V 50Hz for single phase motors, 230/400V 50Hz for three phase motors up to 4kW and 400/690V 50Hz for higher powers.

APPLICATIONS:

Designed for wall or duct installation, they are suitable for:

- Air renewal in buildings and industries.
- Smoke extraction (max 45-50°C).
- Maximum working temperature: 1ph 50°C, 3ph 60°C.

AVAILABLE ON REQUEST:

- Reversible impeller.
- B form impeller (airflow from impeller to motor)
- 60Hz fans and special voltages.

PERFORMANCE CURVE

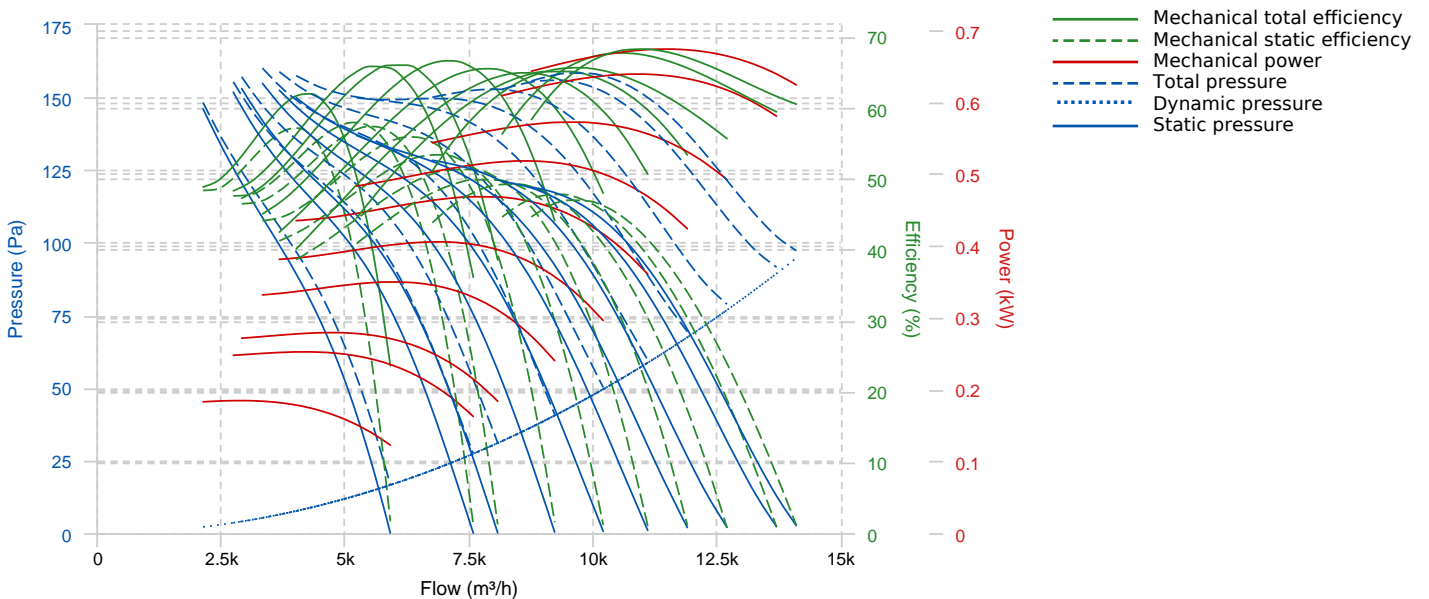

TECHNICAL DATA

Fan

RPM	-	Approx. weight	-	Max. Flow	14110 m ³ /h
-----	---	----------------	---	-----------	-------------------------

DIMENSIONS

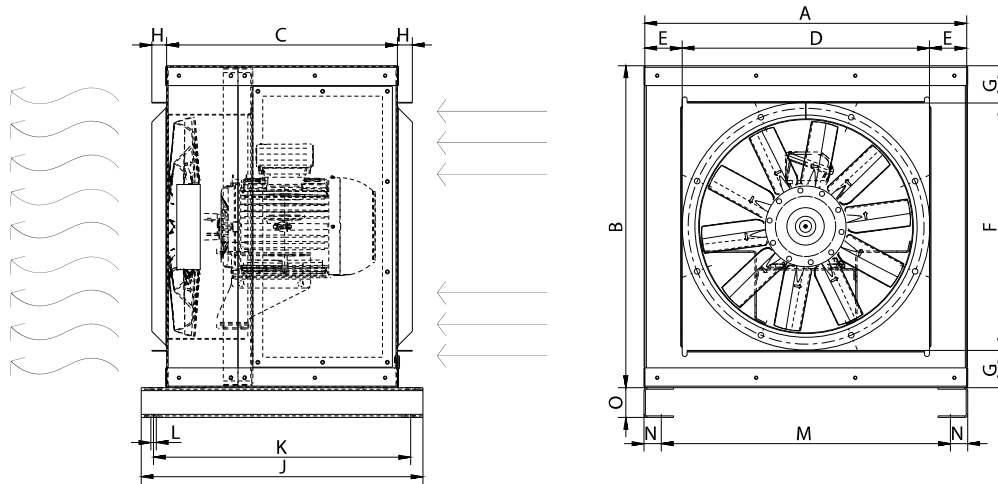

Dimensions (mm)

A	781.5	B	781.5	C	542	D	630	E	76
F	630	G	76	H	30	J	665	K	610
L	11	M	715	N	35	O	60		

WIRING DIAGRAM

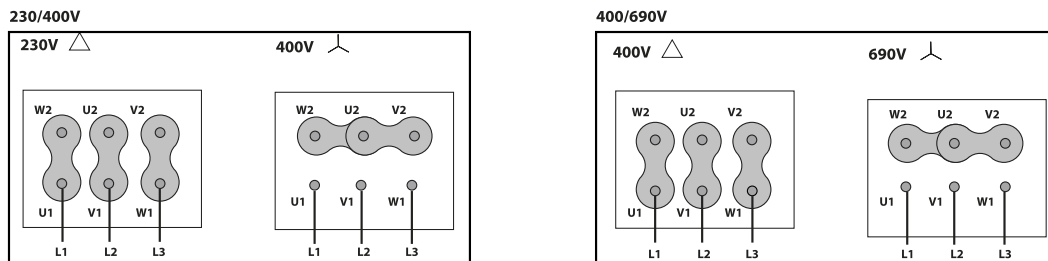

ACCESSORIES



**FREQUENCY SPEED CONTROLLER
SFC (GENERIC)**



**SAFETY SWITCH
INT (GENERIC)**



**ANTI-VIBRATION SPRING BLOCK
AVS (GENERIC)**