

BAC 10 (IN BVFC 15/15) ()

GENERAL DATA

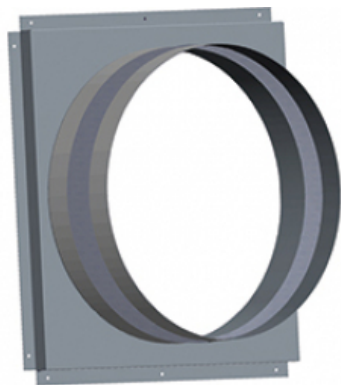

RECTANGULAR-CIRCULAR ANTI-VIBRATION FLANGE

MANUFACTURING FEATURES

- Accessory for connection of DD BOX, BD BOX and BDL FIRE F400 cabinet fans to a circular duct using anti-vibration canvas.
- Fire resistance M0 of -50°C to 200°C in continuous and 400°C/2h.

DIMENSIONS

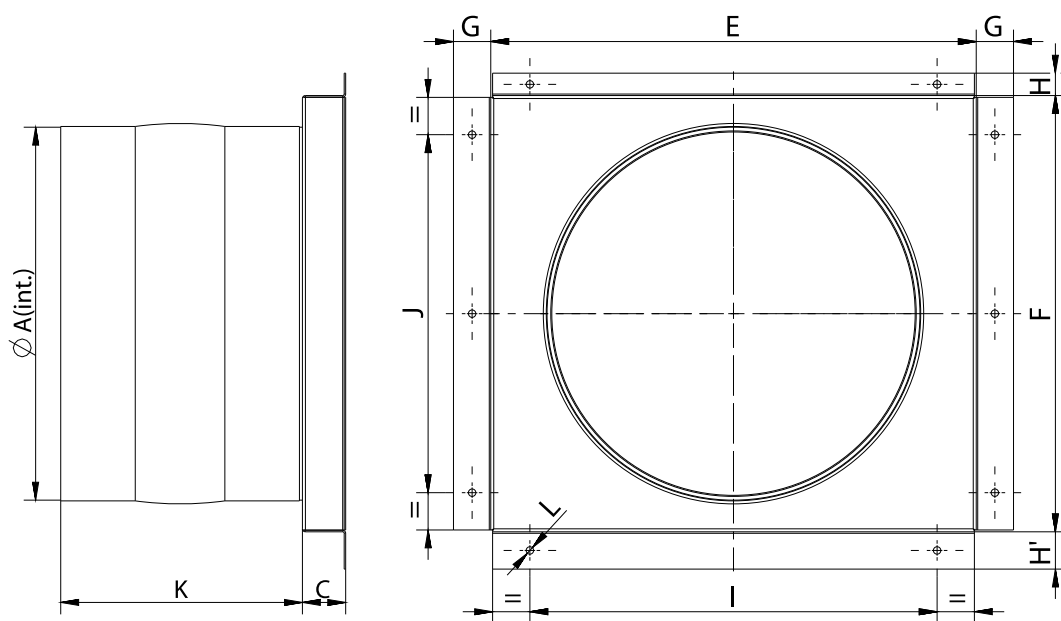

Dimensions (mm)

C	30,5	E	1017,5	F	710,5	G	18,5	H	15
H'	15	I	965	J	658	K	162	ØA	500
ØL	5								